

INTRODUCTION

Understanding brain activity is essential for advancing neuroscience and improving medical treatments. Technologies such as computational modeling and neuroimaging serve as powerful tools for understanding brain function. High-performance computing allows for the rapid analysis of large and complex datasets. Computational modeling software aids in creating simulations of neural activity, enabling scientists to test hypotheses. In combination with technologies such as EEG, these methods provide insights into how the brain processes and responds to different stimuli.

ABSTRACT

To better understand brain activity, it is valuable to integrate experimental data with computing. In this project, we combined parallel computing with the Expanse supercomputer and the NEURON software to analyze EEG data. EEG data was collected using the Muse 2 headset and analyzed with EEGLAB, where artifacts (inconsistencies) were filtered and independent component analysis (ICA) was performed to compare eyes-closed versus eyes-open states. Results showed differences in alpha activity between the two conditions. These findings highlight how combining EEG with computational modeling and supercomputing can be used to make discoveries on brain function.

PARALLEL COMPUTING

Parallel computing uses multiple processors to solve problems more efficiently. Most systems follow the MIMD model (Multiple Instruction, Multiple Data), combining:

- **Shared memory:** Multiple cores share the same memory within a node.
- **Distributed memory:** Data is passed between nodes over a network.

We implemented matrix multiplication on the Expanse supercomputer, using:

- **Vi Editor** to write and edit our code
 - **SLURM scripts** and sbatch to schedule and submit jobs
 - **Unix commands** for compiling, running, and tracking jobs
- Matrix multiplication combines two matrices into a third by computing dot products between rows and columns. To speed this up:
- **OpenMP** was used for multithreading within a single node (shared memory).
 - **MPI** divided tasks across multiple nodes (distributed memory), making it ideal for larger-scale computations.

We also ran the **Jones Model** on 1, 2, 4, and 8 cores via NSG. We recorded the times and plotted **Runtime vs. Number of Processors**.

References: <https://www.sdsc.edu/systems/expanse/index.html>

OpenMP (shared memory) parallel multiply

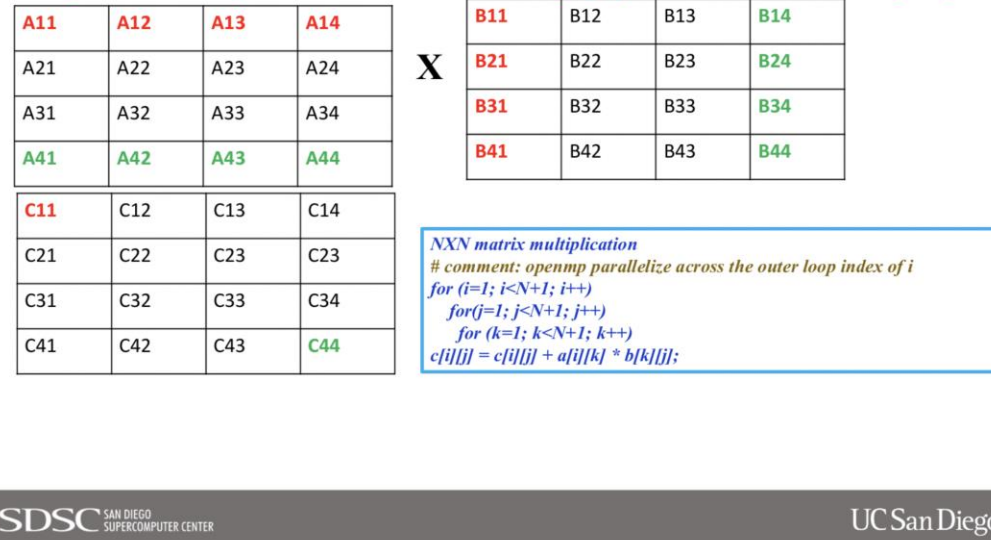

Figure 1. OpenMP matrix multiplication.

MPI Matrix multiply – parallel on two cores

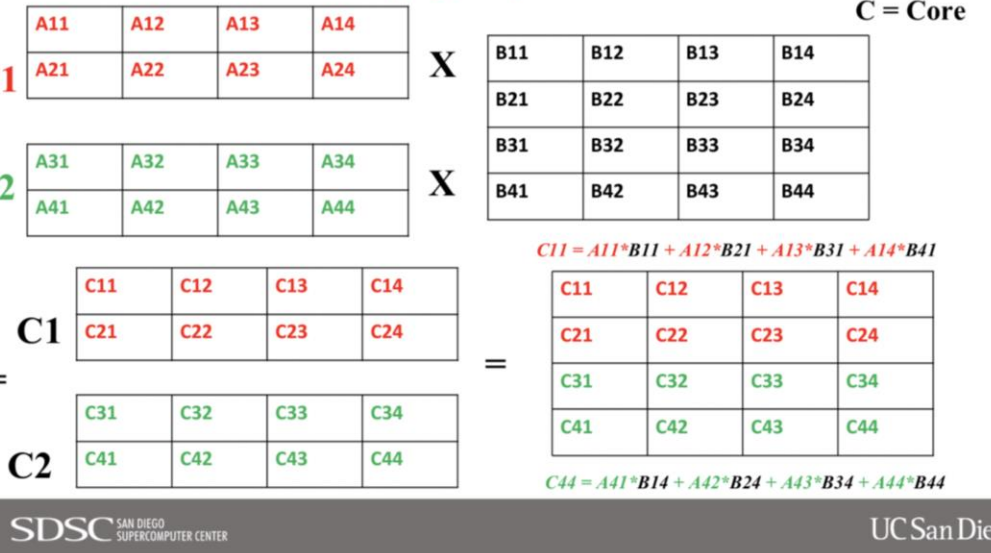

Figure 3. MPI matrix multiplication.

```

$ sbatch SLURM_mpi_hello_world
Submitted batch job 412345

$ squeue -a | grep hzheng
412345 compute R 0:01 1 compute-5-12 hzheng

$ ls -ltr
-rw-r--r-- 1 hzheng sdsc  336 Jul 30 16:43 SLURM_mpi_hello_world
-rw-r--r-- 1 hzheng sdsc  384 Jul 30 16:44 mpi_hello_world.c
-rw-r--r-- 1 hzheng sdsc 1100 Jul 30 16:45 mpi_hello_world
-rw-r--r-- 1 hzheng sdsc   64 Jul 30 16:47 slurm-412345.out

$ cat slurm-412345.out
Hello from processor 0 of 2
Hello from processor 1 of 2
  
```

Figure 5. Output from running MPI code on 2 cores via Expanse and SLURM.

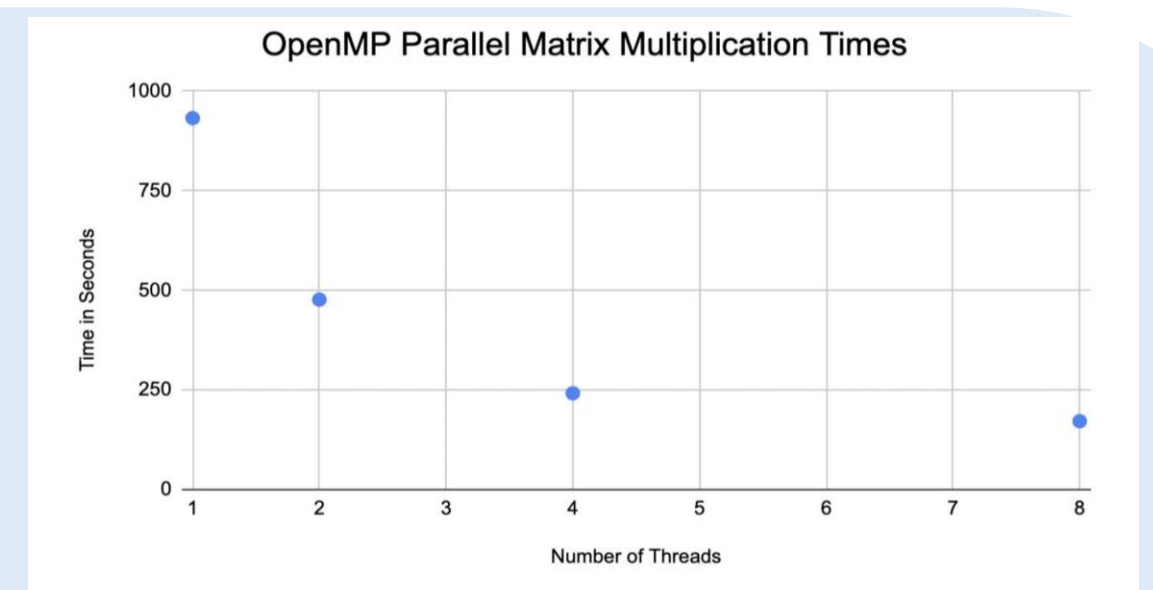

Figure 2. OpenMP Parallel Matrix Multiplication Times

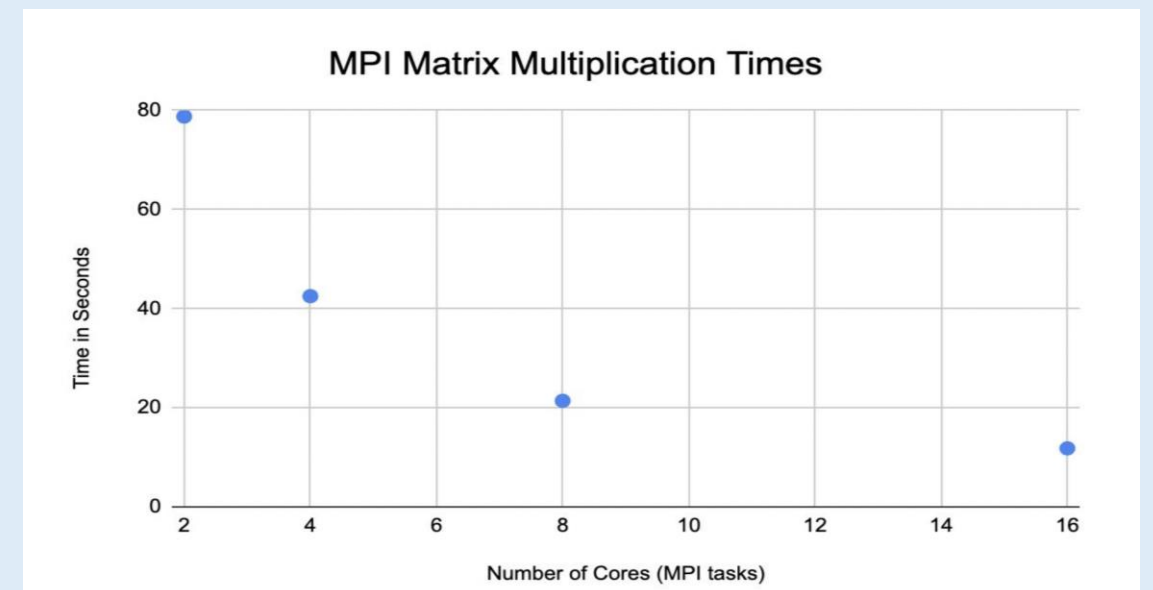

Figure 4. MPI Matrix Multiplication Times

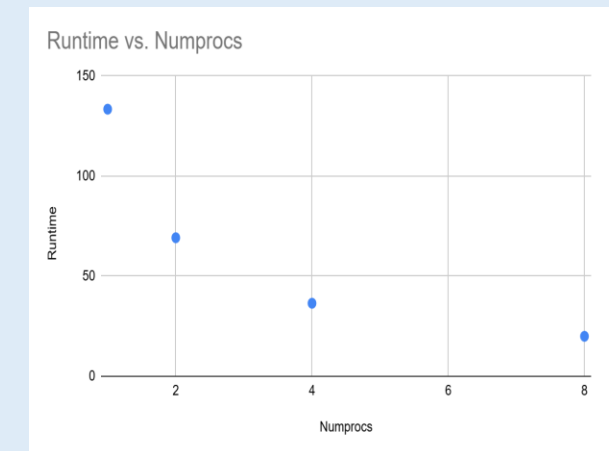

Figure 6. Jones Model showing how runtime decreases as the number of processors increases.

MODELING WITH NEURON

NEURON is a simulation environment for modeling neurons and neural networks. It helps predict experiments, test theories, and study neural behavior using detailed models from research and our own work.

- **Squid Axon Model:** Simulates action potentials by applying current and opening ion channels to show membrane depolarization.
- **Hodgkin-Huxley model:** A combination of a cable and three ion channels: leak, sodium and potassium. Sodium and potassium channels open and close based on membrane potential, modeled by differential equations that predict whether increased current drives the membrane to threshold.

References: <https://www.neuron.yale.edu/neuron/>

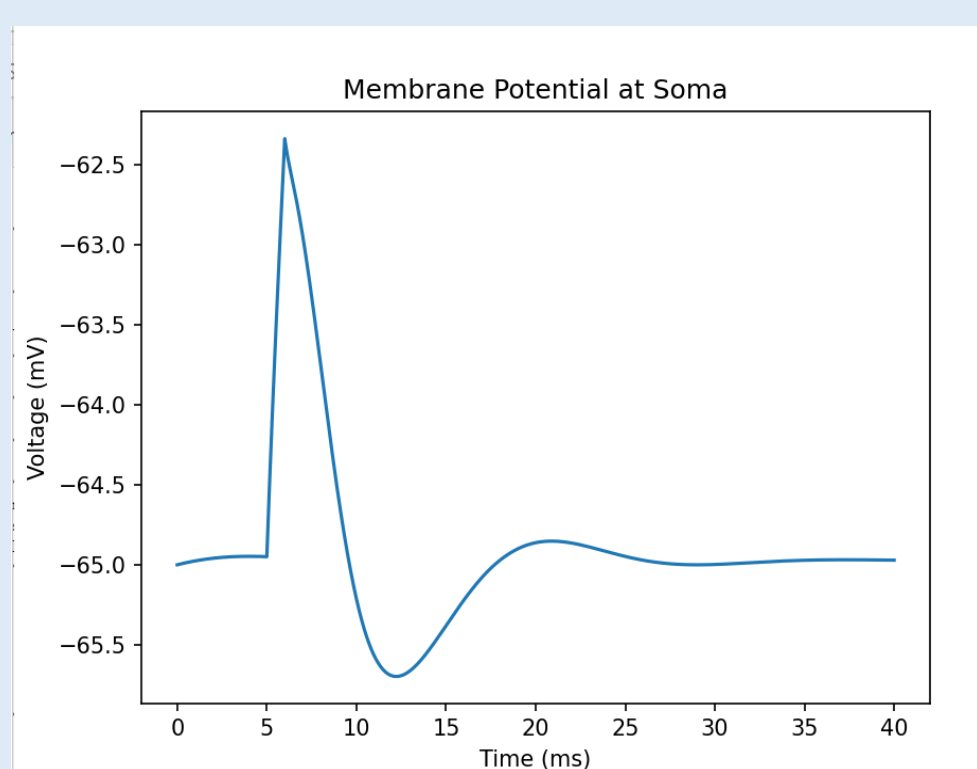

Figure 7. Membrane potential at the squid axon soma showing an action potential with depolarization, repolarization, and hyperpolarization phases.

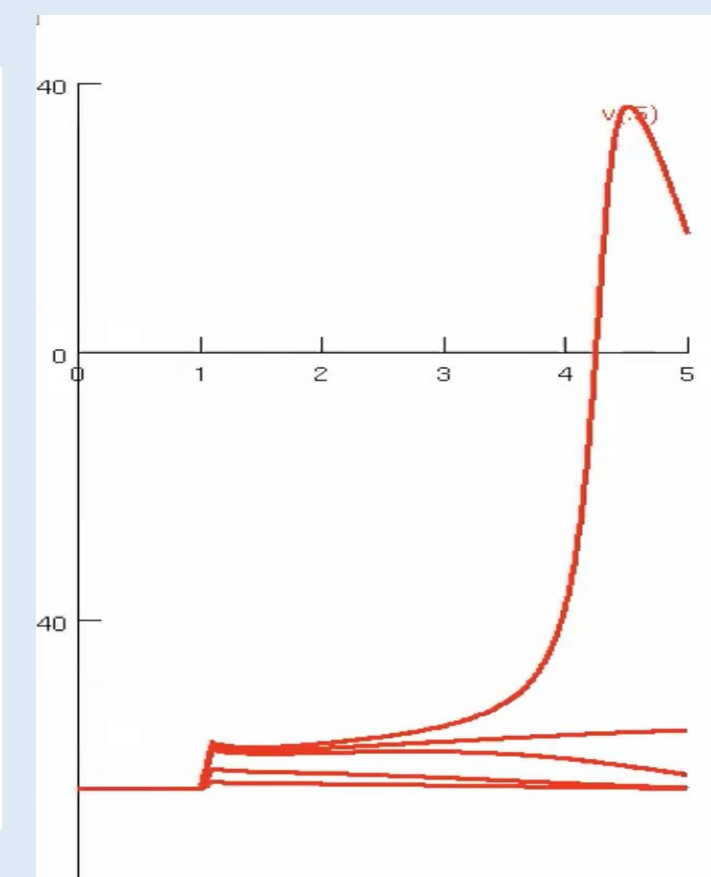

Figure 8. Spike action potential when the current passes the threshold between 0.06-0.07 amp.

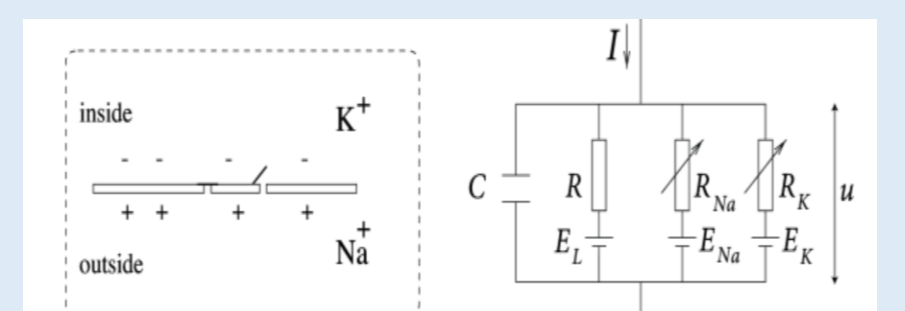

Figure 9. Hodgkin-Huxley diagram showing the neuron membrane is modeled as a circuit.

EEG DATA + ANALYSIS

EEG (electroencephalography) measures brain activity by detecting voltage changes from neuronal firing via scalp electrodes.

- **Purpose:** assess how brainwave activity differs with eyes open vs. eyes closed.
- **Equipment**

- o Muse 2 headset (4 electrodes, 256 Hz, 12-bit depth)
- o Mind Monitor app (records brainwaves)
- o EEGLAB (data cleaning, ICA, and visualization)

- **Methods**

- o Muse 2 placed on subject, electrodes adjusted for contact
- o Recorded 1 min eyes closed, then 1 min eyes open
- o Data processed in EEGLAB (artifact removal, ICA)

- **Results**

- o During eyes-open recording, power in the 8-15 Hz range was relatively higher than in the 15-33 Hz range.
- o The eyes-closed condition showed a smoother downward slope across frequencies, implying more relaxed brain state
- o A slight increase in alpha wave activity (8-12 Hz) was observed during eyes-closed condition, may reflect more relaxed state
- o Slightly higher beta/gamma activity (>20 Hz) with eyes open suggests increased cognitive engagement
- o Unusual sharp spike near 40 Hz in both datasets likely reflects electrical noise, not brain activity

- **Limitations**

- o Low resolution EEG (only 4 electrodes)
- o Noise from movement/environment
- o Small sample size, short duration

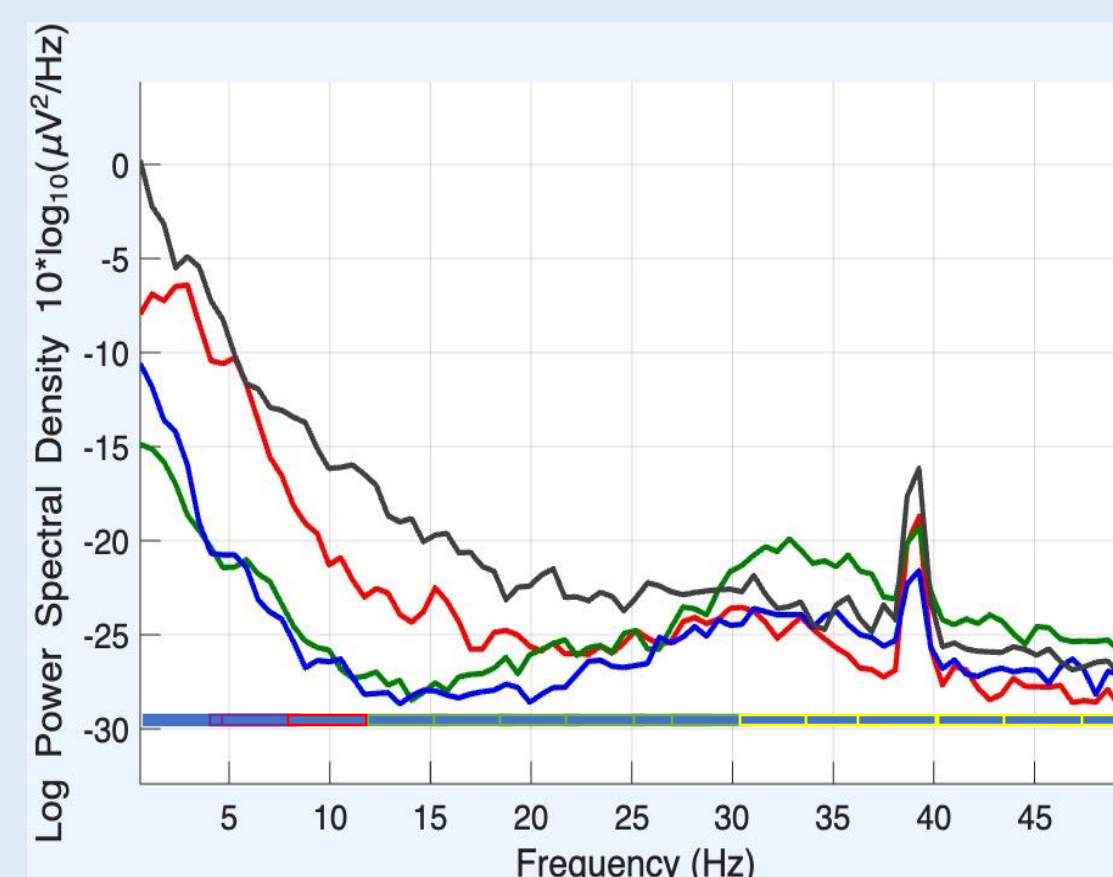

Figure 10. EEG data showing brain activity with eyes open.

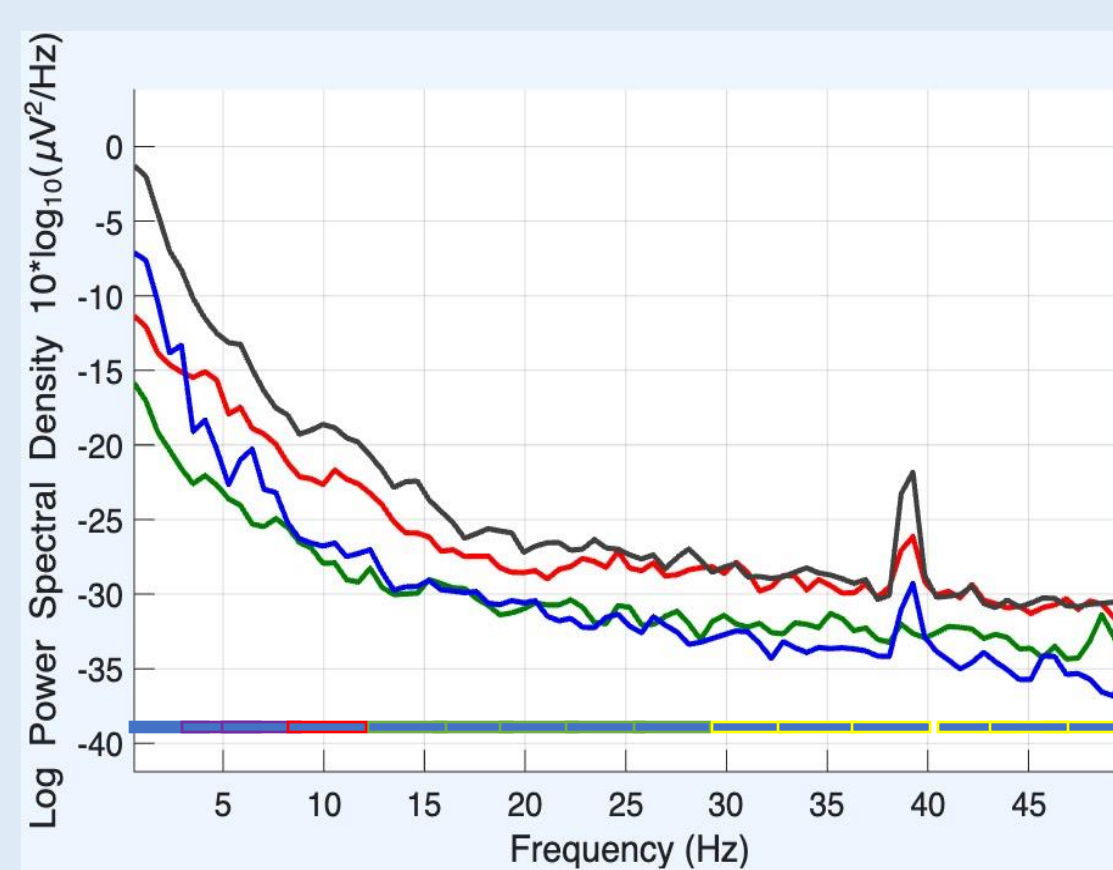

Figure 11. EEG data showing brain activity with eyes closed.

- Delta waves (0.5-4Hz)
- Theta waves (4-8Hz)
- Alpha waves (8-12Hz)
- Beta waves (12-30Hz)
- Gamma waves(30-50Hz)
- <13Hz relaxation
- >13Hz cognitive engagement



Figure 12. Muse headset on a person.